

РАМЕН ЗАПОРЕН И НЕПОВРАТЕН ВЕНТИЛ



STOP & CHECK VALVE

PN 16

DN 15 ... DN 300

РАЗМЕР / SIZE; 1/2" ... 12"

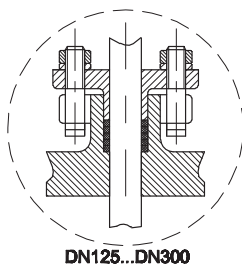
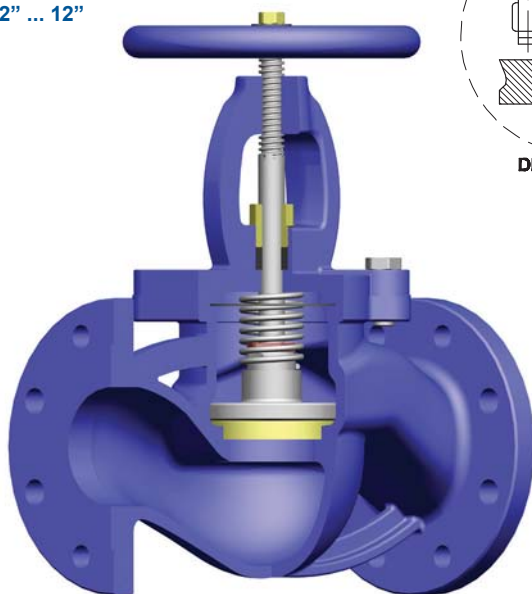

DN125...DN300

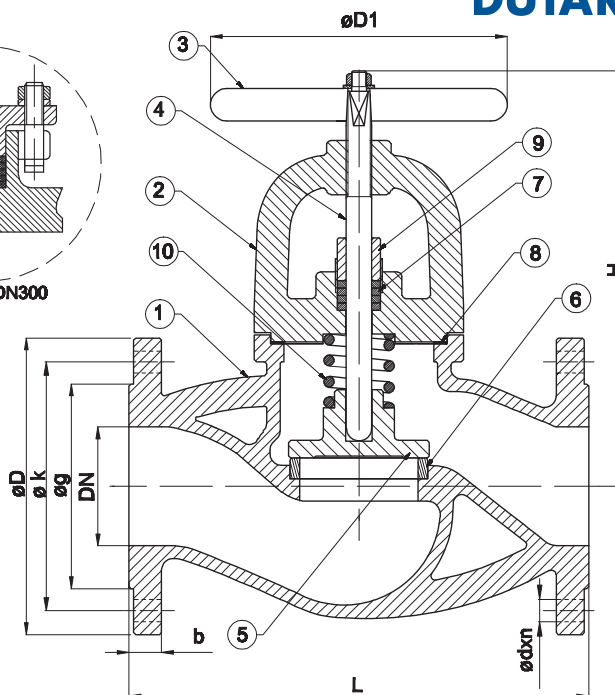

КАРАКТЕРИСТИКИ НА МАТЕРИЈАЛОТ / MATERIALS				
NO	ИМЕ НА ДЕЛОТ	PART NAME	МАТЕРИЈАЛ	MATERIAL
1	ТЕЛО	BODY	GG25 / GGG40.3	GG25 / GGG40.3
2	ПОКЛОПЕЦ	BONNET	GG25 / GGG40.3	GG25 / GGG40.3
3	ТРКАЛО	HANDWHEEL	GG20	GG20
4	ВРЕТЕНО	STEM	НЕРЃОСУВАЧКИ ЧЕЛИК / БРОНЗА	STAINLESS STEEL / BRONZE
5	ДИСК	DISC	DN15 ... 100 НЕРЃОСУВАЧКИ ЧЕЛИК DN125 ... 300 НЕРЃОСУВАЧКИ ЧЕЛИК	DN15 ... 100 SS DN125 ... 300 S137+SS
6	СЕДЛО	SEAT	AISI 304	AISI 304
7	ЗАТВАРАЧ	PACKING	ГРАФИТ	GRAPHITE
8	ЗАПТИВКА	GASKET	КЛИНГЕРИТ	KLINGERIT
9	ЗАПТИВАЧ ЗА ВРЕТЕНО	PACKING GLAND	МЕЦИНГ (CuZn40Pb2)	BRASS (CuZn40Pb2)
10	ПРУЖИНА	SPRING	НЕРЃОСУВАЧКИ ЧЕЛИК	STAINLESS STEEL

ДИЗАЈН/ DESIGN	TS 10873
РАЗМЕР ПОМЕГУ ПРИРАБНИЧКИ СПОЈ FLANGE AND THEIR JOINTS	TS ISO 7005-2 BS EN 1092-2
РАЗМЕР ПОМЕГУ ПРИРАБНИЦИ FACE TO FACE DIMENSIONS	TS EN 558-1 SERI 1
ИСПИТУВАЊЕ/ TESTS	TS EN 12266-1

T-0210 / T-0220

РАМЕН ЗАПОРЕН И НЕПОВРАТЕН ВЕНТИЛ Stop & Check Valve																	
Номинален Притисок Nominal Pressure		PN 16														PN 10	
Номинален Дијаметар Nominal Diameter		DN	15	20	25	32	40	50	65	80	100	125	150	200	250	300	
Димензии на вентилот Valve Dimensions	L	130	150	160	180	200	230	290	310	350	400	480	600	730	850		
	Min.Strok	5		6	8	10	13	16	20	25	32	40	50	63	75		
	H.max	200	200	230	240	275	310	310	345	395	455	535	680	800	870		
Димензии на прирабница Flange Dimensions	PN 16	D1	125				160			200			250	315		400	500
		D	95	105	115	140	150	165	185	200	220	250	285	340	405	460	
		k	65	75	85	100	110	125	145	160	180	210	240	295	355	410	
		g	46	56	65	76	84	99	118	132	156	184	211	266	319	370	
		b	14	16		18			20		22	24	26		30	32	
		d	14				19					23			28		
Број на отвори / Hole Qty	n	8						8				12					
Тежина/ Weight	Kg.	4	4.5	5.5	7.5	10	13.5	21	29	41.5	63	89	155	259	357		

ТЕМПЕРАТУРА/ПРИТИСОК TEMPERATURE / PRESSURE					ПРИМЕНА • Топла и ладна вода • Зовриена вода • Парена вода • Воздух под притисок • Флуиди кои не содржат киселина и не запаливи течности • Морска вода	APPLICATIONS • Hot and cold water • Superheated water • Steam, superheated steam systmes • Pressurized air • Fluid excluding acid & non Flammable fluids • Sea Water
°C	-10.....+ 120	200	250	300		
PN	16	13	11	10		

"Поради постојан развој на нашите производи, ние го задржуваме правото да го менуваме нашиот произведен дизајн или изградба без претходна најава."

"Due to continuous development of our products, we reserve the right to modify our product design or construction without prior notice."

